

Sanitari
Sanitaryware
Sanitaires
Sanitäreanlagen
Sanitarios
Сантехника

glow



Scheda di preinstallazione
CONSERVARE CON CURA

Instructions for preinstallation
KEEP CAREFULLY

Fiche technique de pre-installation
CONSERVER AVEC SOIN

Vorinstallationsblatt
SORGFÄLTIG AUFBEWAHREN

Ficha técnica de preinstalación
CONSERVAR CON CUIDADO

Схема предварительной установки
ХРАНИТЬ БЕРЕЖНО

AVVERTENZE

- Tutte le misure sono espresse in millimetri
- I disegni riportati non sono in scala.

WARNING

- All measures are in millimetres
- The show drawings are not scaled

AVERTISSEMENTS

- Toutes les mesures sont exprimées en millimètres.
- Les dessins reportés ne sont pas à l'échelle.

WARNUNG

- Sämtliche Maßangaben in mm.
- Die Zeichnungen sind nicht im Maßstab

ADVERTENCIAS

- Todas las medidas vienen en milímetros
- Los dibujos representados no son a escala.

ПРЕДУПРЕЖДЕНИЯ

- Все размеры указаны в миллиметрах
- Рисунки приведены вне масштаба

bidet sospeso • wall-mounted bidet
 bidet suspendu • Hängebidet
 bidé suspendido • навесное биде

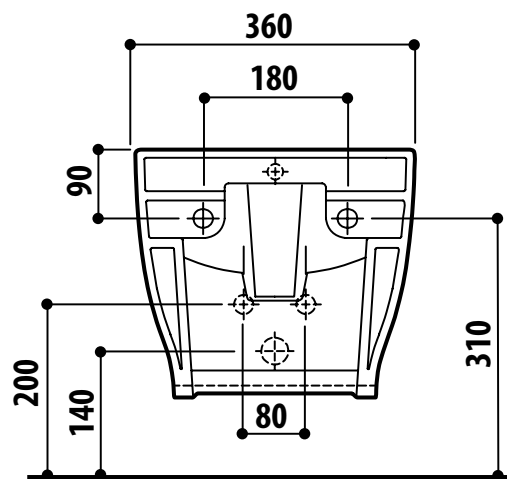
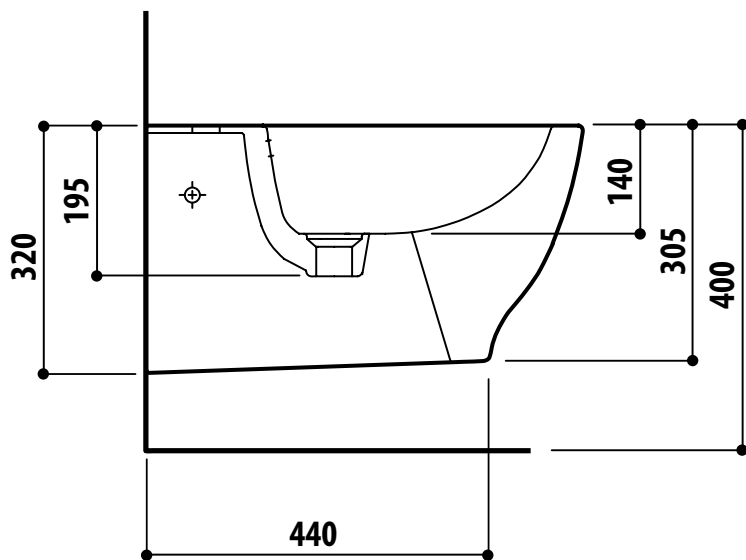
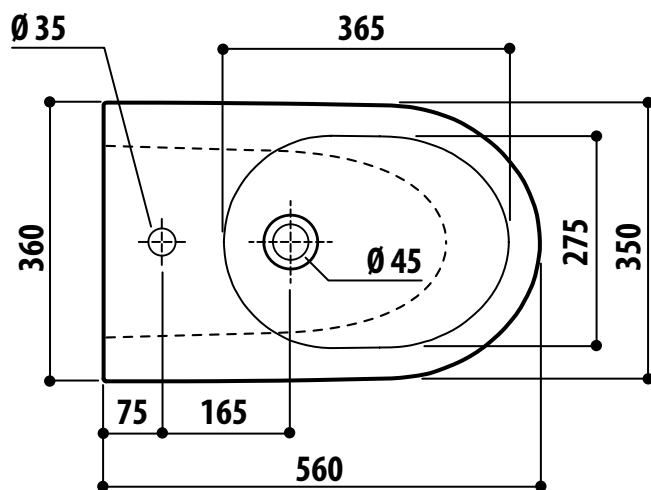

mm

vaso sospeso • wall-mounted wc pan
 cuvette de toilette suspendue • Hängetoilette
 inodoro suspendido • навесной унитаз

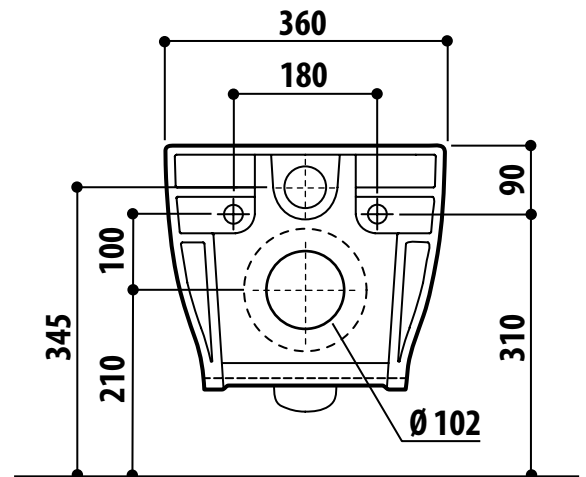
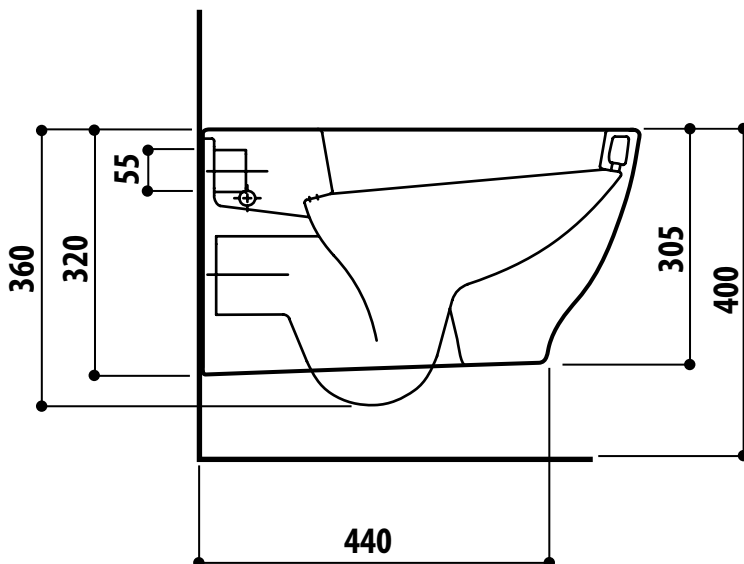
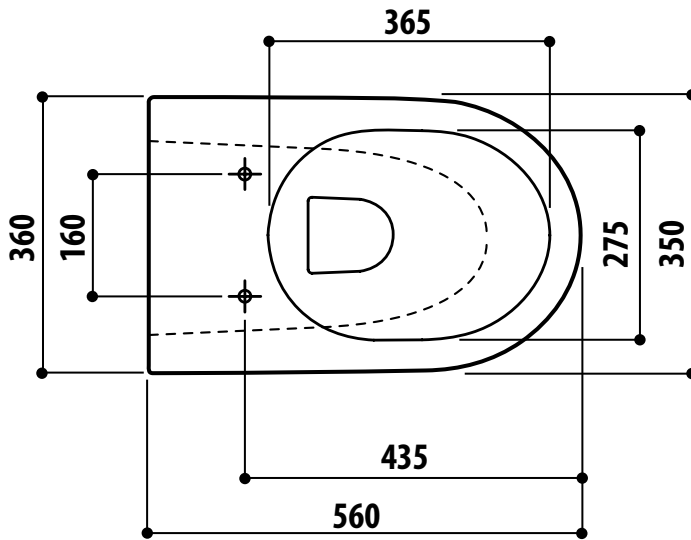

mm

bidet a terra a filo parete · floor-standing back-to-wall bidet
bidet au sol au ras du mur · Wandbündiges Standbidet
bidé sobre suelo contra pared · напольное биде, устанавливаемое на уровне стены

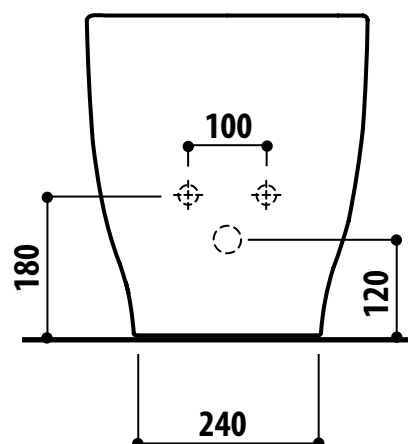
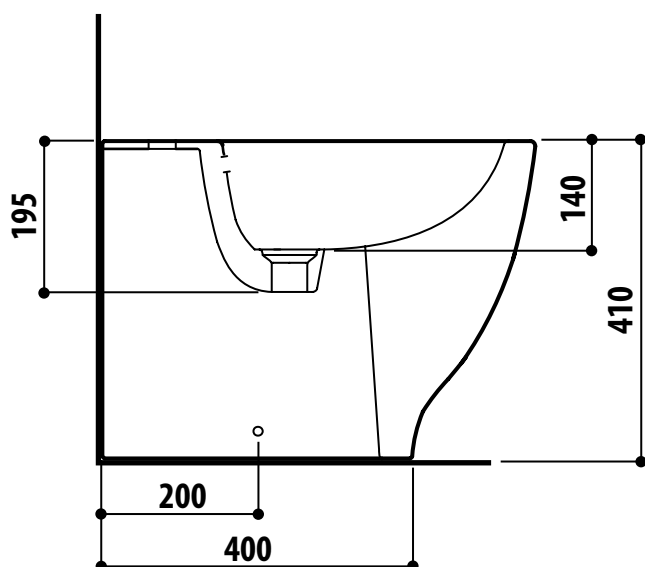
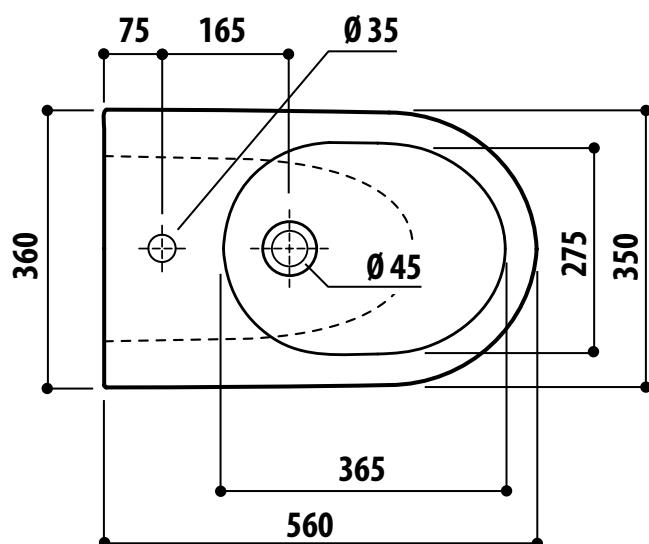

mm

**vaso a terra a filo parete · floor-standing back-to-wall wc pan
 cuvette de toilette au sol au ras du mur · Wandbündige Standtoilette
 inodoro sobre suelo contra pared · напольный унитаз, устанавливаемый на уровне стены**

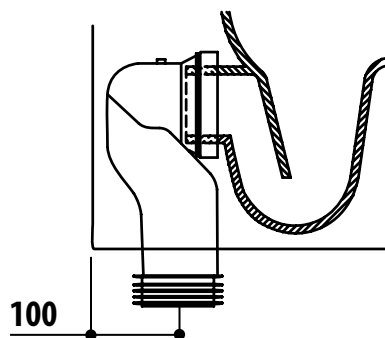
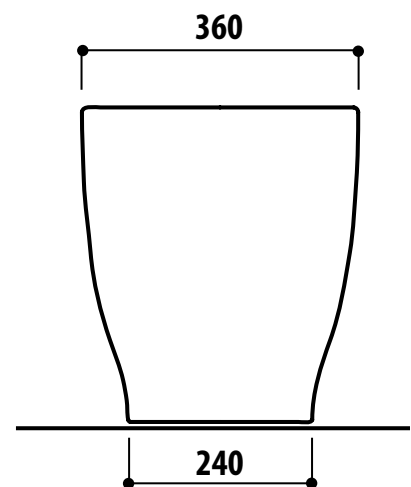
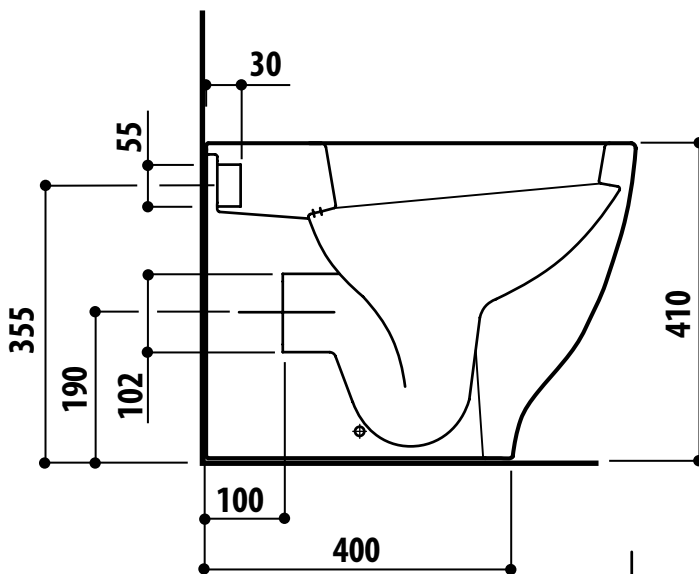
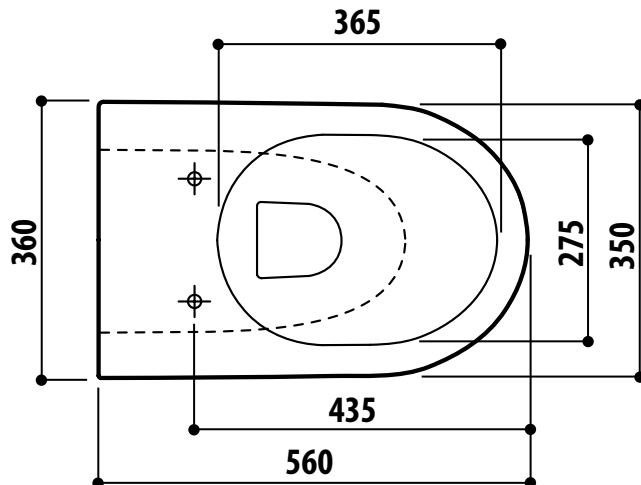

con curva tecnica
 with 90° wc pan connector
 avec raccord arrondi technique
 mit Ablaufbogen
 con codo de salida
 с технической кривой

lavabo d'appoggio • countertop basin
 lavabo à poser • Aufsatzwaschbecken
 lavabo de apoyoado • опорная раковина

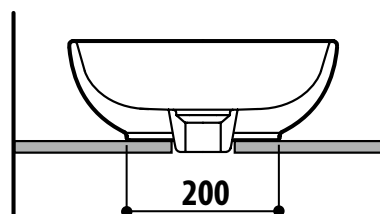
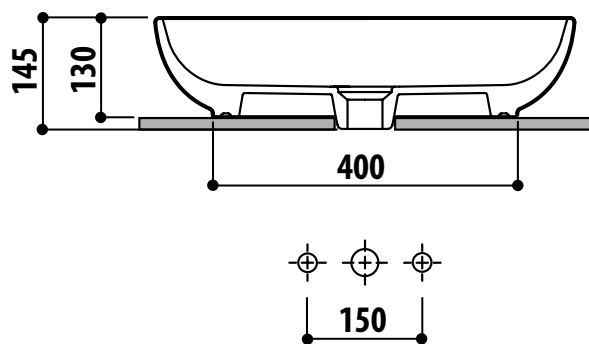
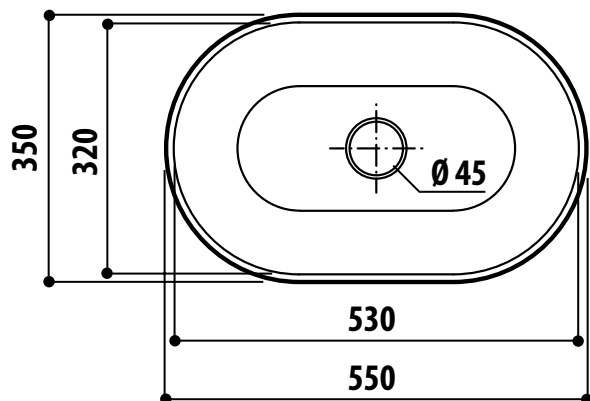

mm

lavabo d'appoggio · countertop basin
 lavabo à poser · Aufsatzwaschbecken
 lavabo de apoyoado · опорная раковина

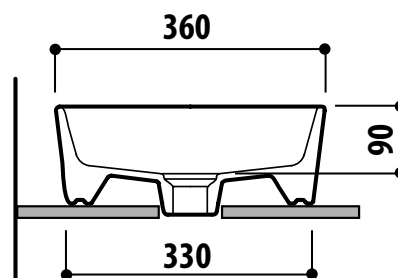
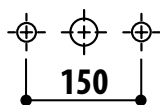
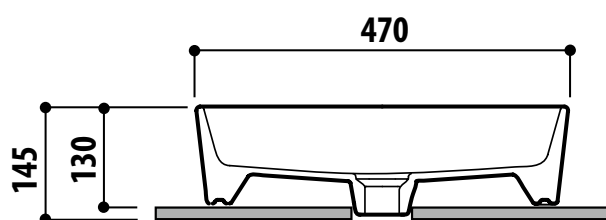
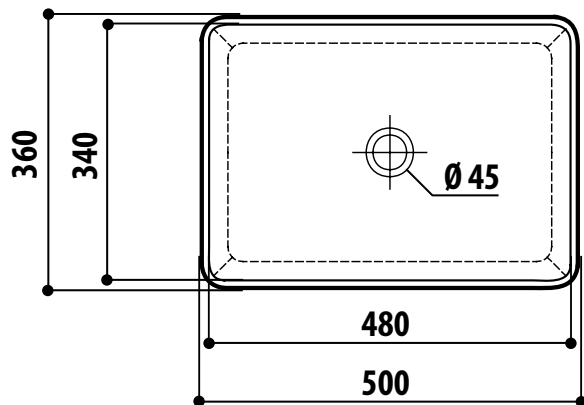



JACUZZI EUROPE S.p.A.

Socio Unico

Direzione e Coordinamento

Jacuzzi Brands, Corp. (USA)

S.S. Pontebbana, km 97,200

33098 Valvasone Arzene (PN) ITALIA

Phone + 39 0434 859111- Fax + 39 0434 85278

www.jacuzzi.eu - info@jacuzzi.it



Jacuzzi UK

Jacuzzi® Spa and Bath Ltd

Old Mill Lane - Low Road - Hunslet

Leeds LS10 1RB

Jacuzzi® Hot tubs: hottubsales@jacuzziemea.com

Jacuzzi® Bathrooms: retailersales@jacuzziemea.com

Phone: +44 (0)113 2727430 - Fax: +44 (0)113 2727445

Jacuzzi Whirlpool GmbH

A Company of Jacuzzi Brands, Corp. (USA)

Humboldtstr. 30/32

D-70771 Leinfelden-Echterdingen

Phone: 0049 (0)711 933247-20 Technik/Service/Kundendienst/Ersatzteile (After Sales)

Phone: 0049 (0)711 933247-40 Verkauf/Preise/Finish Products

Fax 0049 (0)711 933247-50

www.jacuzzi.eu

info-de@jacuzzi.it

Jacuzzi France s.a.s.

8 Route de Paris

03 300 Cusset Cedex (FRANCE)

Phone: +33 (0)4 70 30 90 50 - Fax: +33 (0)4 70 97 41 90

info@jacuzzi france.com

Jacuzzi Bathroom España, SL

Sociedad unipersonal

A Company of Jacuzzi Brands, Corp. (USA)

Jacuzzi® Bathroom España

C/ Comte urgell, 252 local 4

08036 Barcelona

Phone: +34 932 385 031- Fax +34 932 385 032

www.jacuzzi.es

info-es@jacuzzi.it

I dati e le caratteristiche non impegnano la Jacuzzi Europe S.p.A., che si riserva il diritto di apportare tutte le modifiche ritenute opportune senza obbligo di preavviso o di sostituzione

The data and characteristics indicated do not oblige Jacuzzi Europe, who reserves the right to make the necessary changes they feel opportune without forewarning or substitution

Les caractéristiques indiquées, n'engagent pas la Jacuzzi Europe, qui se réserve le droit d'apporter toutes les modifications qu'elle jugera opportune sans obligation de préavis ou de remplacement

Die Angaben sind für Jacuzzi Europe nicht bindend. Änderungen, die dem Fortschritt dienen, halten wir uns vor

Los datos y características indicadas no comprometen a Jacuzzi Europe que se reserva el derecho de aportar todas las modificaciones que considere oportunas sin obligación de preaviso o de sustitución

Приведенные данные и характеристики являются для фирмы Jacuzzi Europe S.p.A. необязательными. Фирма оставляет за собой право внесения всех тех изменений, которые будут признаны необходимыми, без обязательства предварительного уведомления или замены.

JACUZZI EUROPE S.p.A. • all rights reserved • JULY 2015

