

LAMPADA SOLAR SQUARE

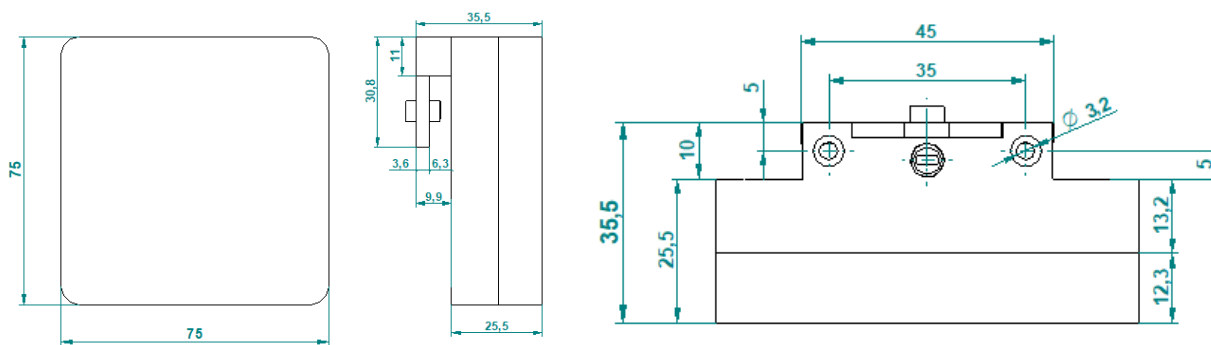

Lampada SOLAR, realizzata in ABS cromato, con diffusore in policarbonato.

Illuminazione a led CLII-IP44-3,9W-230V-50Hz, modulo led non sostituibile, 459 Lumen - 4000°K

Fissaggio diretto allo specchio con grano, non necessita di alimentatore CLASSE ENERGETICA (E)

Lamp SOLAR, realized in ABS chromed, with diffuser in polycarbonate.

Led lighting CLII-IP44-3.9W-230V-50Hz, non-replaceable LED module, 459 Lumen - 4000°K

Direct fixing to the mirror with set crew, act without driver, ENERGY CLASS (E)